

Achieve in-line adhesive application productivity with fully-automated applicator.



SD-900

Reduce costs associated with downtime and excessive adhesive waste, while simultaneously achieving productivity, with the SD-900 fully-automated inline adhesive applicator. With intermittent or continuous adhesive application options, this fully-automated applicator was designed to seamlessly integrate into existing production lines and makes applying Glue Dots Brand Adhesives a fast and affordable option when speed and accuracy are imperative for project success.

Able to provide a quick return on investment, the affordable SD-900 requires little maintenance and increases safety by eliminating burn risks associated with hot melt systems. Available in both left and right configurations, important features of the SD-900 include:

- 90-feet per-minute product speed
- Application rate up to 300 adhesives per minute
- Encoder following (conveyor mounted for automatic speed matching)
- +/- 3/32" placement accuracy
- Holds up to 8,000 adhesive patterns per roll
- Adjustable adhesive pattern count placement

Because the SD-900 is a fully-automated applicator, there are standard requirements that facilities should have in place before setting up this unit:

- 110/120VAC power supply, 50/60 Hz (Standard 3-prong wall - in U.S.)
- 220VAC Single Phase model will be available for sales outside of U.S.
- 24VDC, PNP Sensor (to detect the product)
- 40 psi air supply
- Max 6 amps

In addition, the SD-900 needs to be mounted via an adjustable stand or directly onto a conveyor. Glue Dots offers an adjustable T-Base stand with a low profile base that enables it to nest under your product conveyor system. The T-Base stand provides optimal height adjustment, within a 35-inch range, allowing you to move the SD-900 unit to the exact height needed for your specific application. Purchasing the stand is optional, but highly recommended to maximize productivity.

Well received in automated environments, the low maintenance SD-900 in-line applicator works for a variety of jobs in a wide range of industries. Glue Dot products are a preferred solution when other adhesive systems prove to be messy, ineffective or difficult to use.

SD-900 Applications

Packaging

Secure product's orientation prior to packaging or shrink wrapping or close lightweight packaging



Printing & Mailing

Attach promotional items & gift cards, close brochures or use as an alternative to wafer seals



Pharmaceutical/Nutraceutical

Secure product information sheets or outserts

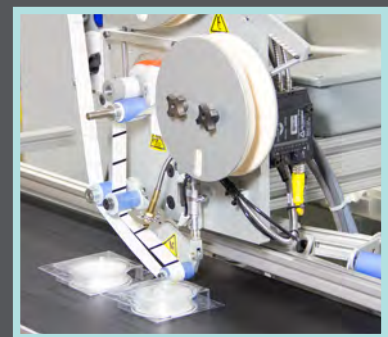

SD-900

Dispenser Specifications

Weight:	50.0lb
Height:	20.46"
Length:	19.47"
Width:	8.58"
Materials:	Stainless Steel, Aluminum
Power:	120/220 VAC, 50/60 Hz

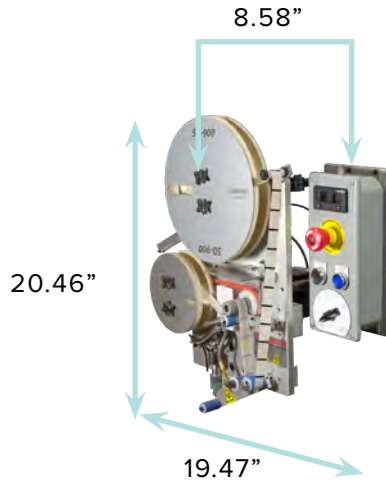

Right Configuration

The SD-900 is available in right or left configurations to accommodate individual production lines.

By following the instructions, located on the front of the applicator, the SD-900 can be set-up and efficiently loaded/reloaded with relative ease.



SD-900 Compatible Standard Glue Dots Adhesives

Item #	Diam.	Tack Level	Bond	Profile
ED21-404	1/2"	Medium	Removable	Low
ED31-404	1/2"	High	Semi-Permanent	Low
ED41-404	1/2"	Super High	Permanent	Low

The SD-900 fully-automated adhesive applicator has three standard adhesive options, but is also compatible with custom adhesives, which are available upon request.

SD-900 Stand Specifications

Height:	66.47"
Length:	45.75"
Width:	44.56"
Materials:	Stainless Steel, Aluminum

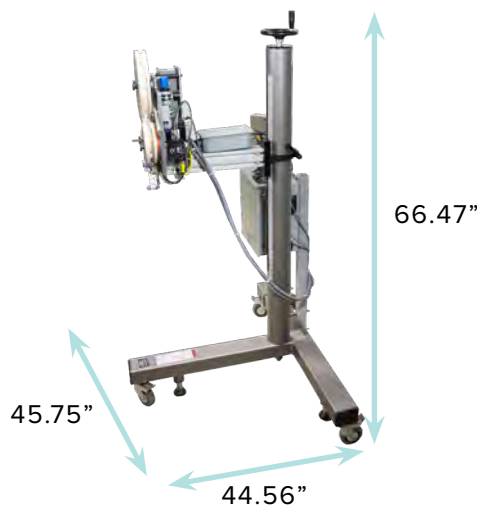

The right adhesive solution for your application.

Established in 1997, Glue Dots International (GDI) forever altered the adhesive industry when it launched the unprecedented pressure-sensitive, preformed adhesives product line globally known today as Glue Dots®.

With the most pressure-sensitive adhesive pattern experience in the industry, GDI can help you find the right adhesive and application equipment solution to meet your specific needs.

Our experienced account managers and engineers are available to provide adhesive recommendations based upon your application. Sample adhesives may be supplied for testing.

Want to find out more about how Glue Dots can help your next project? Visit us at GlueDots.com or call 888-688-7131.

Follow us online.



Glue Dots® Brand Adhesives and application equipment are sold through authorized distributors of Glue Dots International.

Glue Dots® is a registered trademark of Glue Dots International. U.S. and foreign patents pending.